

Product Specification

10Gbps 1310nm SFP+ Optical Transceiver, 10Km

1.Feature

- SFP+ package with LC connector
- 1310nm DFB Laser and PIN photo detector
- Up to 10km transmission on SMF
- Power dissipation < 1W
- LVPECL compatible data input/output interface
- Low EMI and excellent ESD protection
- laser safety standard IEC-60825 compliant
- Compatible with RoHS
- Compatible with SFF8472

2.Application

- Ethernet
- Fiber Channel

3.Absolute Maximum Ratings

Parameter	Symbol	Minimum	Maximum	Units
Storage Temperature	Tst	-40	+85	°C
Supply Voltage	Vcc	0	+3.6	V
Operating Relative Humidity	RH	0	85	%

4. Operation Environment

Parameter		Symbol	Min	Typical	Max	Units
Supply Voltage		V _{cc}	3.15		3.45	V
Operating Case Temperature	Commercial	T _c	-5		+70	°C
Power Dissipation					1	W
Data Rate				10.3125		Gbps

5. Optical Characteristics

(Ambient Operating Temperature -5°C to +70°C, V_{cc} = 3.3 V)

Parameter	Symbol	Min.	Typ.	Max.	Units
Transmitter Section					
Center Wavelength	λ_0	1290	1310	1330	nm
Side-Mode Suppression Ratio	SMSR	35	-	-	dB
Average Output Power	P _o	-8	-	+0.5	dBm
Extinction Ratio	E _r	3.5	-	-	dB
Dispersion Penalty				3.2	dB
Relative Intensity Noise	RIN _{12OMA}			-128	dB/Hz
Total jitter	T _j	IEEE 802.3ae			
Receiver Section					
Center Wavelength	λ_0		1310		nm
Receiver Sensitivity	R _{sen}			-12.5	dBm
Stressed Sensitivity	R _{sen}			-10.5	dBm
Receiver Overload	R _{ov}	-3			dBm
Return Loss		12			dB
LOS Assert	LOS _A	-20			dBm
LOS Dessert	LOS _D			-17	dBm
LOS Hysteresis		0.5		4	

6. Electrical Characteristics

(Ambient Operating Temperature -5°C to +70°C, Vcc =3.3 V)

Parameter	Symbol	Min.	Typ.	Max.	unit
Transmitter Section					
Input Differential Impedence	Zin	90	100	110	Ohm
Data Input Swing Differential	Vin	180		700	mV
TX Disable	Disable	2.0		Vcc	V
	Enable	0		0.8	V
TX Fault	Assert	2.0		Vcc	V
	Deassert	0		0.8	V
Receiver Section					
Output differential impedance	Zout		100		Ohm
Data output Swing Differential	Vout	300		800	mV
Rx_LOS	Assert	2.0		Vcc	V
	Deassert	0		0.8	V

7. Diagnostics

Parameter	Range	Accuracy	Unit	Calibration
Temperature	-10 ~ 75	±3	°C	Internal
Voltage	0 ~ VCC	0.1	V	Internal
Bias Current	0 ~ 100	0.5	mA	Internal
Tx Power	-8 ~ 1	±1	dBm	Internal
Rx Power	-18 ~ 0	±1	dBm	Internal

8. EEPROM INFORMATION (A0)

Addr	Field Size (Bytes)	Name of Field	HEX	Description
0	1	Identifier	03	SFP
1	1	Ext. Identifier	04	MOD4
2	1	Connector	07	LC
3-10	8	Transceiver	10 00 00 00 00 00 00 00	Transmitter Code
11	1	Encoding	06	64B66B
12	1	BR, nominal	67	10000M bps

13	1	Reserved	00	
14	1	Length (9um)-km	0A	
15	1	Length (9um)	00	
16	1	Length (50um)	00	
17	1	Length (62.5um)	00	
18	1	Length (copper)	00	
19	1	Reserved	00	
20-35	16	Vendor name	57 49 4E 54 4F 50 20 20 20 20 20 20 20 20 20 20	TRANSFIBRES
36	1	Reserved	00	
37-39	3	Vendor OUI	00 00 00	
40-55	16	Vendor PN	xx xx xx xx xx xx xx xx xx xx xx xx xx xx xx xx	ASC II
56-59	4	Vendor rev	31 2E 30 20	V1.0
60-61	2	Wavelength	05 1E	1310nm
62	1	Reserved	00	
63	1	CC BASE	XX	Check sum of byte 0~62
64-65	2	Options	00 1A	LOS, TX_DISABLE, TX_FAULT
66	1	BR, max	00	
67	1	BR, min	00	
68-83	16	Vendor SN	00 00 00 00 00 00 00 00 00 00 00 00 00 00 00 00	Unspecified
84-91	8	Vendor date code	XX XX XX 20	Year, Month, Day
92-94	3	Reserved	00	
95	1	CC_EXT	XX	Check sum of byte 64~94
96-255	160	Vendor specific		

9.Pin Description

Pins	Name	Discription	NOTE
1	VeeT	Transmitter Ground	

2	Tx Fault	Transmitter Fault Indication	1
3	Tx Disable	Transmitter Disable	2
4	MOD DEF2	Module Definition 2	3
5	MOD DEF1	Module Definition 1	3
6	MOD DEF0	Module Definition 0	3
7	RS0	Not Connected	
8	LOS	Loss of Signal	4
9	RS1	Not Connected	
10	VeeR	Receiver Ground	
11	VeeR	Receiver Ground	
12	RD-	Inv. Received Data Output	5
13	RD+	IReceived Data Output	5
14	VeeR	Receiver Ground	
15	VccR	Receiver Power	
16	VccT	Transmitter Power	
17	VeeT	Transmitter Ground	
18	TD+	Transmit Data Input	6
19	TD-	Inv. Transmit Data Input	6
20	VeeT	Transmitter Ground	

Notes:

- TX Fault is an open collector output, which should be pulled up with a 4.7k~10k resistor on the host board to a voltage between 2.0V and Vcc+0.3V. Logic 0 indicates normal operation; logic 1 indicates a laser fault of some kind. In the low state, the output will be pulled to less than 0.8V.
- TX Disable is an input that is used to shut down the transmitter optical output. It is pulled up within the module with a 4.7k~10k resistor. Its states are:
 Low (0~0.8V): Transmitter on
 (>0.8V, <2.0V): Undefined
 High (2.0~3.465V): Transmitter Disabled
 Open: Transmitter Disabled
- MOD-DEF 0,1,2 are the module definition pins. They should be pulled up with a 4.7k~10k resistor on the host board. The pull-up voltage shall be VccT or VccR.
 MOD-DEF 0 is grounded by the module to indicate that the module is present
 MOD-DEF 1 is the clock line of two wire serial interface for serial ID
 MOD-DEF 2 is the data line of two wire serial interface for serial ID
- LOS is an open collector output, which should be pulled up with a 4.7k~10k resistor on the host board to a voltage between 2.0V and Vcc+0.3V. Logic 0 indicates normal operation; logic 1 indicates loss of signal. In the low state, the output will be pulled to less than 0.8V.
- These are the differential receiver output. They are internally AC-coupled 100 differential

- lines which should be terminated with 100 (differential) at the user SERDES.
6. These are the differential transmitter inputs. They are AC-coupled, differential lines with 100 differential termination inside the module.

10. Recommended Application Circuit

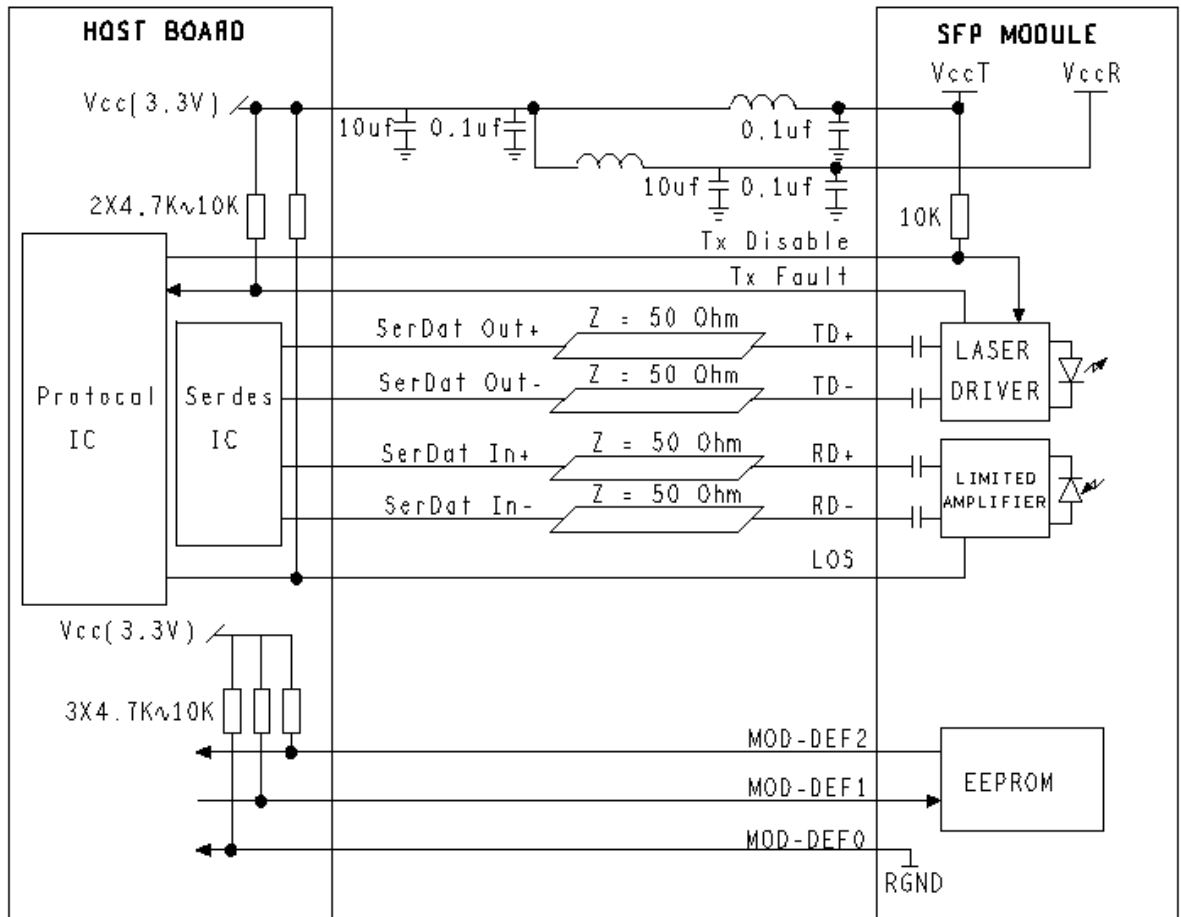

11. Outline drawing (mm)

